

CODE/ADDENDA APPROVED
 RELEASED FOR PRODUCTION
 Q.C. _____ DATE _____

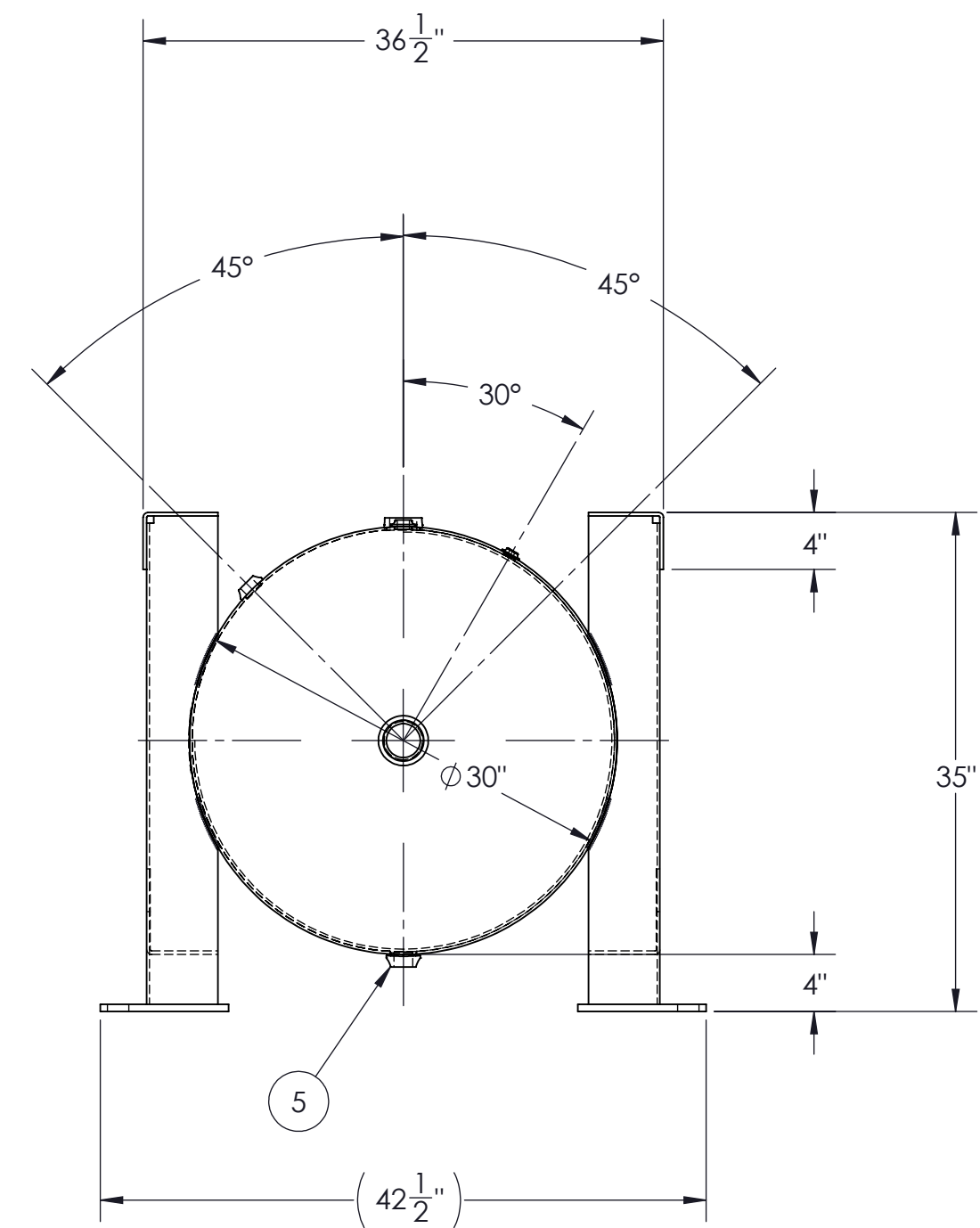
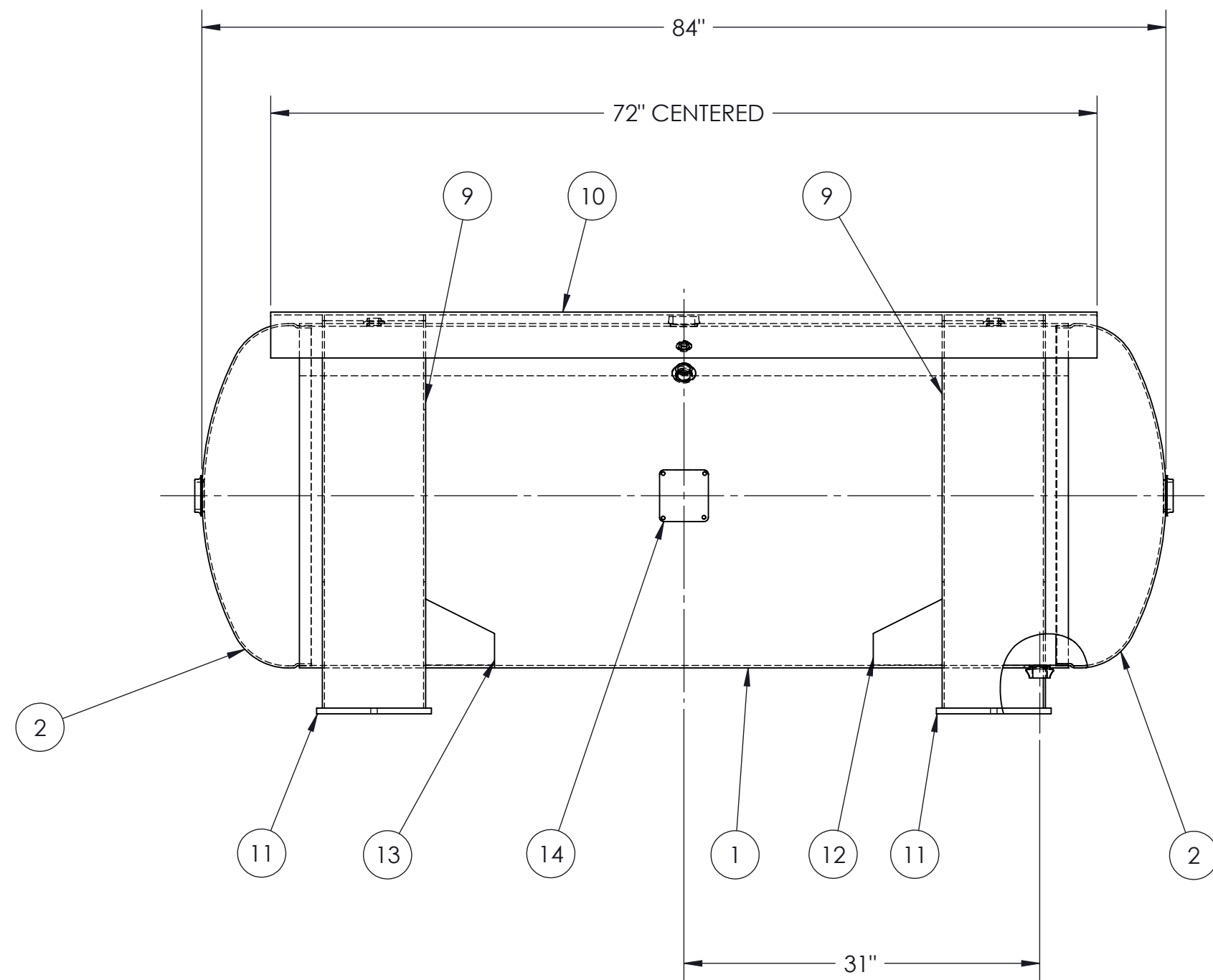
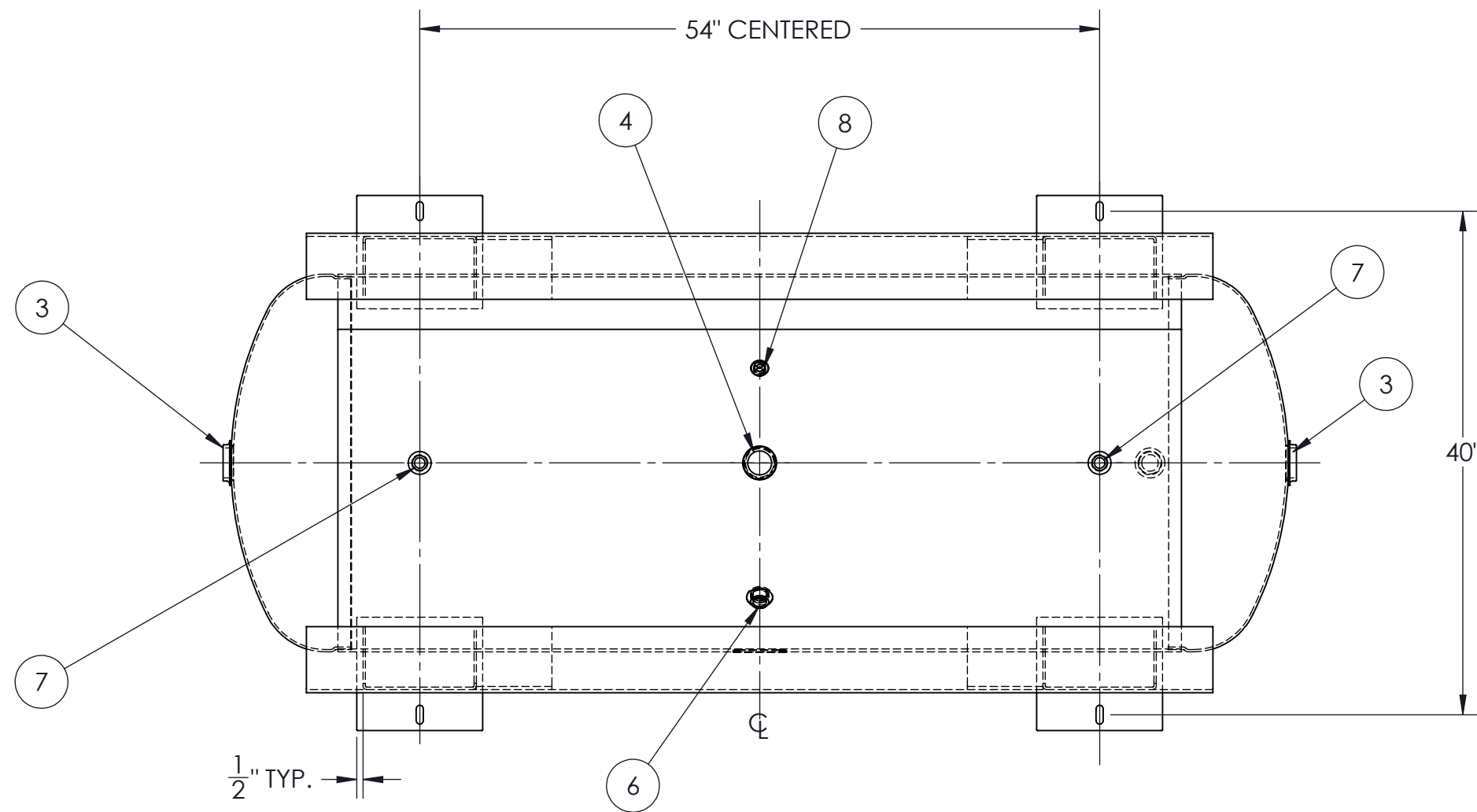

ITEM NO.	QTY.	DESCRIPTION	Material	PART NUMBER
1	1			
2	2			
3	2	2"-NPT 1500# FLAT FLANGE	SA-181-70	F10440
4	1	1 1/2"-NPT 1500# RADIAL FLANGE	SA-181-70	F30317
5	1	1"-NPT 1500# RADIAL FLANGE	SA-181-70	F32270
6	1	3/4"-NPT 1500# RADIAL FLANGE	SA-181-70	F32275
7	2	1/2"-NPT 1500# FLAT FLANGE	SA-181-70	F32268
8	1	1/8"-NPT 1500# FLAT FLANGE	SA-181-70	F32308
9	4	FORMED LEG	C1010	A94481
10	2	1/4" FORMED RAIL	C1008	A94482
11	4	1/2" FOOT PLATE	C1008	A94480
12	2	1/4" LIFTING ANGLE	C1008	A94483
13	2	1/4" LIFTING ANGLE	C1008	A94483
14	1	ASME DATA PLATE	C1010	A20910

NOTES

SPECIFICATIONS

O.D. 30 LGTH. 84
 MAWP 200 PSI @ 650 °F

GAL. 240
 WT. 818.7#
 CORR ALW 0 SH. 0 HD.
 CODE: ASME Section VIII, Div.1
 LATEST EDITION & ADDENDA

CRN F0628.1C

WELD DETAILS: M-1932

STD. TOLERANCES (UNLESS OTHERWISE NOTED): M-2461



GRASSHOPPER TANK

DRAWN BY _____ DATE _____ SCALE: NONE

APP. BY _____ DATE _____ DRAWING NO.

302652

REV.	BY	DESCRIPTION	DATE	APPROVED